

CathCAD® User Guide

**CathCAD®: The Software for Developing Your Next MicroCatheter
Roth Technologies, LLC**

Copyright© by Roth Technologies, LLC

All rights reserved.

Licensed and potential subscribers of the CathCAD® Software are allowed to make copies of this manual (as required) for the User's of the CathCAD® Software. Otherwise, no parts of this work may be reproduced without the written permission of Roth Technologies, LLC.

Products that are referred to in this document may be either trademarks and/or registered trademarks of the respective owners. The publisher and the author make no claim to these trademarks.

While every precaution has been taken in the preparation of these documents, the publisher and the author assume no responsibility for errors or omissions, or for damages resulting from the use of information contained in this document or from the use of programs and source code that may accompany it. In no event shall the publisher and the author be liable for any loss of profit or any other commercial damage caused or alleged to have been caused directly or indirectly by this document.

CONTACT INFORMATION

Roth Technologies, LLC
14111 Bluff Grove Drive
San Antonio, TX 78216
Phone: 210-380-9890

Email: sales@cathcad.com
Web: www.cathcad.com

TABLE OF CONTENTS

I. Introduction 4

II. Reference Documents 4

III. Running the Program 4

IV. Using the CathCAD® System 5

V. Material and Braid Wire Data 11

VI. Exporting Modeling Results to Microsoft Excel 11

VII. Coil Reinforced Modeling 15

VIII. Multi-Stranded Braid Layer Designs 16

IX. Hybrid Braid Modeling 17

X. Pick Count Macro and Graphing 18

XI. Material Blending 21

XII. Saving Project Designs 22

XIII. CathACCESS® 24

XIV. Reporting Errors or to Request Feature Updates 24

I. Introduction

Welcome to the CathCAD® Modeling Software User Guide. This manual will provide you basic instructions on how to use the SOFTWARE and applies to both the **CathCAD® Standard** and **CathCAD® Advanced** versions of the SOFTWARE.

Modeling systems that depart from the SOFTWARE base assumptions may and will result in numerical results that are "different" from reality. It is important to understand that the SOFTWARE model outputs should be validated by or in conjunction with building and testing the actual device.

II. Reference Documents

- **CathCAD® End User License Agreement (EULA)**, Roth Technologies
- **Fundamentals of CathCAD®**, Roth Technologies (PowerPoint Presentation)
- **Introduction to Composite Tubing Design**, Roth Technologies
- **CathCAD® Installation Guide**, Roth Technologies
- *Design Considerations in Small Diameter Tubing*, Roth, **MDDI**, January, 2001

III. Running the Program

After the SOFTWARE is installed, the User may double click the SOFTWARE Program Icon to execute it. A splash screen similar to the one shown appears when the program is executed. The SOFTWARE will only run under Windows XP, Windows 7, Windows 8, and Windows 10. Previous versions of the Windows Operating System are NOT supported.

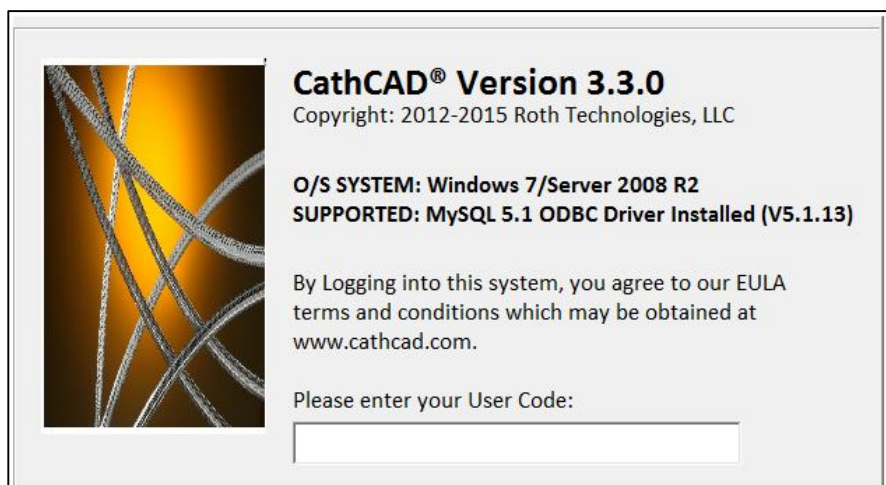

The SOFTWARE login screen indicates what version of the Windows operating system you are utilizing as well as the MySQL ODBC driver that is loaded on your computer.

Your company has been provided a ten to sixteen character length passcode for logging into the **CathCAD®** system.

You may submit a request to sales@cathcad.com to change your passcode character string. This character string identifies your company within the **CathCAD®** system. The EULA prohibits you from sharing this character string to any unauthorized users. If you happen to lose control of your passcode, contact sales@cathcad.com and we will change your login passcode.

IV. Using the CathCAD® System

This section applies to both **CathCAD® Standard** and **CathCAD® Advanced** versions of the SOFTWARE. The SOFTWARE was developed and compiled to run under the Microsoft Windows Operating System. Its use and execution should be easily understood by an individual who is familiar with the design and construction of layered composite tubing.

This section provides basic instructions on how to use the SOFTWARE. This guide assumes that the User is familiar with designing composite tubing. If you are not familiar with designing composite tubing, the reader is referred to the document, **Introduction to Composite Tubing Design**, which is available for download from our website. The data entry process for the SOFTWARE consists of the following sequential steps:

- Enter the Tubing Inner Diameter (ID)
- Enter the Number of Layers in the design
- Enter the information required for each layer in the composite tube design
- Select the COMPUTE button
- Select the EXPORT button if you wish to export the computed results to Microsoft Excel

Each of these steps are now developed in this section of the document.

Tubing ID (units of inches)

Enter the tubing inner diameter in this field. The system will ensure that only numbers are entered into this field. The system will not allow you to enter negative numbers or alpha numeric characters.

CathCAD(R) MODELING SOFTWARE			
STATUS BAR			
Enter Tubing Inner Diameter			
DIMENSIONS			
Tubing ID (inches)	0.020	Tubing OD (inches)	
Number of Layers		Bend Radius (inches)	2.000

Tubing OD (units of inches)

The SOFTWARE calculates the Outside Diameter (OD) based on the Tubing Inner Diameter and each individual layer thickness. You cannot enter any data into this field.

Number of Layers

This field is used to specify the number of layers in the composite tubing design. The minimum number of layers in a design is one (1) and the maximum number of layers in a design is six (6). The inner most layer (the layer nearest the ID of the tube design) is identified as Layer 1. When this field has been entered, the system will update to show only the entry fields for the number of layers that you entered in this field.

In the example shown below the User has entered the number of layers in the design as three (3).

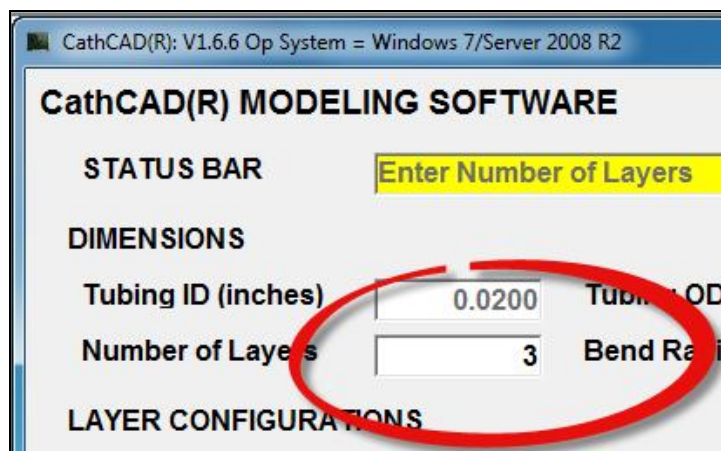

Bend Radius

This parameter is utilized to compute the ovalized shape of the composite tube when it is subjected to a bend radius. At the defined Bend Radius (in inches), the SOFTWARE computes the major axis dimension (X-DIM) and minor axis dimension (Y-MIN) per the Brazier algorithm. This output is useful to determine if an item (i.e. guide wire) will bind in your design when the design is going through a particular bend radius.

If the User enters a bend radius SMALLER than the computed kink radius, the SOFTWARE enters the larger of the two figures of merit (User entered bend radius and computed kink radius) automatically.

The default value for this parameter is 2 inches.

The screenshot shows the CathCAD(R) MODELING SOFTWARE interface. At the top, the title bar reads "CathCAD(R): V1.6.6 Op System = Windows 7/Server 2008 R2". Below the title bar, the main window title is "CathCAD(R) MODELING SOFTWARE".

The interface is divided into several sections:

- STATUS BAR:** A yellow highlighted box contains the text "Enter Number of Layers".
- DIMENSIONS:** This section contains four input fields:
 - Tubing ID (inches): 0.0200
 - Tubing OD (inches): 0.0200 (circled in red)
 - Number of Layers: 3
 - Bend Radius (inches): 2.000 (circled in red)
- LAYER CONFIGURATIONS:** This section is partially visible at the bottom of the screenshot.

Layered Construction

The fields associated with each composite tubing layer are (a) the Configuration, (b) the Wall Thickness, and (c) the Layer (Matrix) Material. If the Layer Configuration is defined as a BRAID layer, then the additional fields of Braid Wire Size, # of Wires in the CW and CCW direction, and Pick Count become visible and must be specified as well. In the example shown below:

1. Layer 1 and Layer 3 are set to a configuration as a NonBraid. As a result, the expected inputs to define a NonBraid layer is the wall thickness of the layer and the layer material.
2. Layer 2 is defined to be a Braided Layer.
 - a. The expected inputs are the layer (matrix) material, the Braid Wire Size, the total number of Braid Wires, and the Pick Count.
 - For **CathCAD® Standard** -- enter the total number of Braid Wires (CW plus CCW)
 - For **CathCAD® Advanced** -- enter the number of Braid Wires in the CW direction and the number of Braid Wires in the CCW direction
 - b. The wall thickness of the layer is computed automatically based on the braid wire size
 - c. The braid angle and the surface area coverage of the braid layer are computed values.
3. Layer 1 is defined as the layer closest (next to) the Tubing Inner Diameter
4. Layer 3 is defined as the layer located at the outer most layer of the design.
5. The inner and/or outer layers CANNOT be a braid, hybrid, or coil reinforced layer. If you design truly has a braid wire layer on the inner diameter of the design, then you will need to model Layer 1 as a NonBraid layer with a very thin wall thickness (i.e. 0.0001 inches).

The screen shot below shows a three layer composite tubing design that has NOT been filled out.

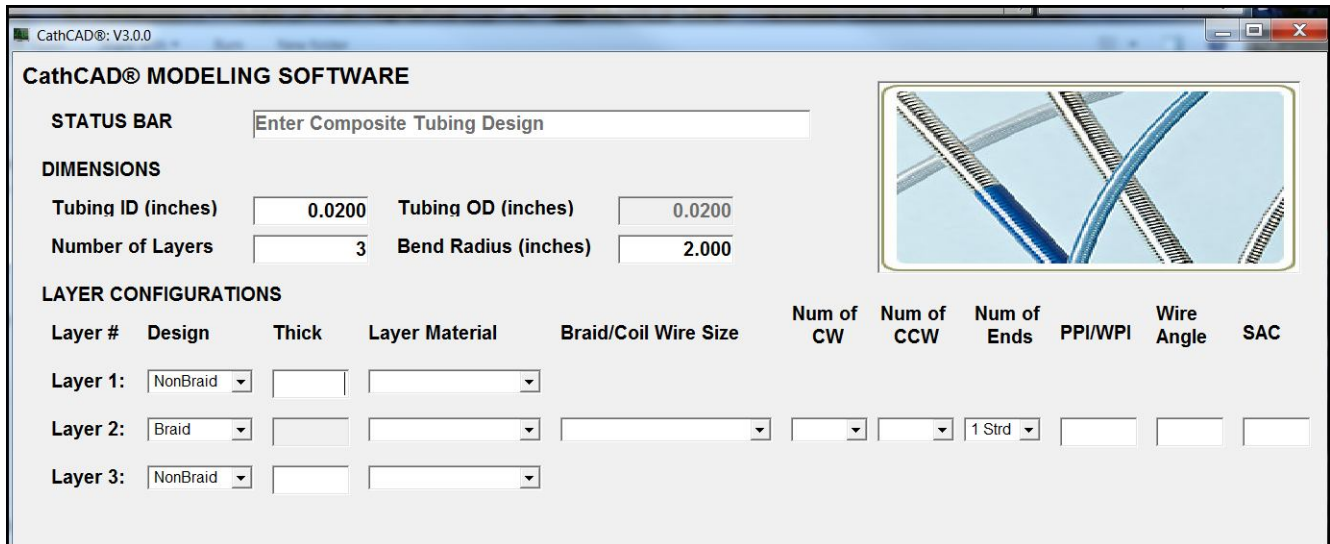

The screen shot below shows the three layer composite tubing design after being completed by the User.

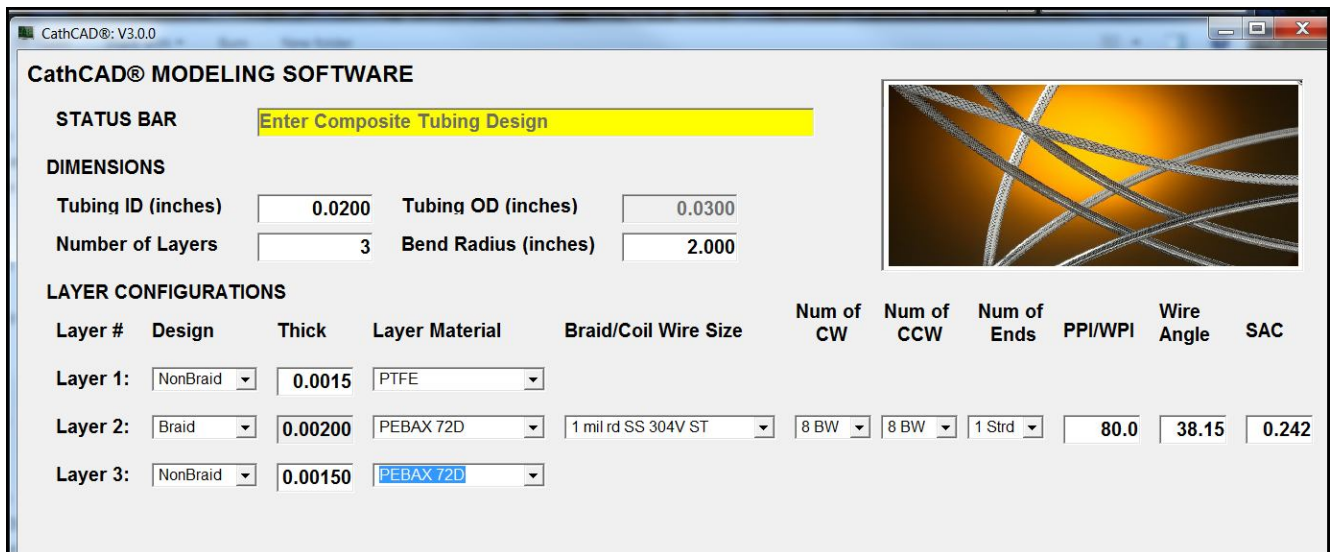

If you know the braid angle of your design but not the Pick Count, you can enter trial values of the pick count into the SOFTWARE until your desired braid angle shows up on the screen. The computation from Braid Angle to Pick Count is nearly instantaneous.

After the required values have been entered, the User can select the **COMPUTE** button to generate the model outputs. The screen shot below shows the computed results after selecting the **COMPUTE** button. Note that the **EXPORT TO EXCEL** function has become active after the model has been computed.

CathCAD® MODELING SOFTWARE

STATUS BAR Enter Composite Tubing Design

DIMENSIONS

Tubing ID (inches) 0.0200 Tubing OD (inches) 0.0300
 Number of Layers 3 Bend Radius (inches) 2.000

LAYER CONFIGURATIONS

Layer #	Design	Thick	Layer Material	Braid/Coil Wire Size	Num of CW	Num of CCW	Num of Ends	PPI/WPI	Wire Angle	SAC
Layer 1:	NonBraid	0.0015	PTFC							
Layer 2:	Braid	0.00200	PEFRAX 72D	1 mil rd SS 304V ST	8 BW	8 BW	1 Strd	80.0	38.15	0.242
Layer 3:	NonBraid	0.00150	PEBAX 72D							

MODEL OUTPUT

EI (lbs-inch**2)	0.00898	KR (inches)	0.134 / 0.144
EA (lb)	110.50	X ID (inches)	0.0200
GJ (lbs-inch**2)	0.01967	Y ID (inches)	0.0200
Burst (psi):	506 / 962	Tensile (lbs)	2.21 / 12.33
Ext Press (psi):	506	Torque (lbs-in)	0.3535

COMPUTE

EXPORT TO EXCEL **QUIT**

Error Correction

If the User enters incorrect values into the required fields, the SOFTWARE will automatically update the value as applicable. Examples of this update is as follows:

1. Entering nonnumeric data into applicable fields (for example: entering the letter "A" into the Tubing ID field)
2. Entering negative numbers
3. Entering large number into applicable fields
4. Entering a braid size/# of wires/pick count which results in a SAC (braid surface area coverage) that exceeds a maximum limit (set to approximately 80 percent but we can adjust this value).

In these cases, the SOFTWARE intelligently intercepts the data being entered into the field, reviews it for applicability, and adjusts the values as applicable. In most cases, the SOFTWARE deletes the information being entered if it thinks it is incorrect, thus forcing the User to reenter/correct the data.

If you select the **COMPUTE** button before all the fields have been properly entered, the SOFTWARE will identify the **FIRST** field that is incorrect/empty and will highlight it in RED for two to three seconds. Correct your mistake(s) and then select with the **COMPUTE** button.

In the example below, the Layer 1 thickness was left blank. The SOFTWARE has highlighted this field to bring it to the operator's attention. The STATUS BAR also displays an error message.

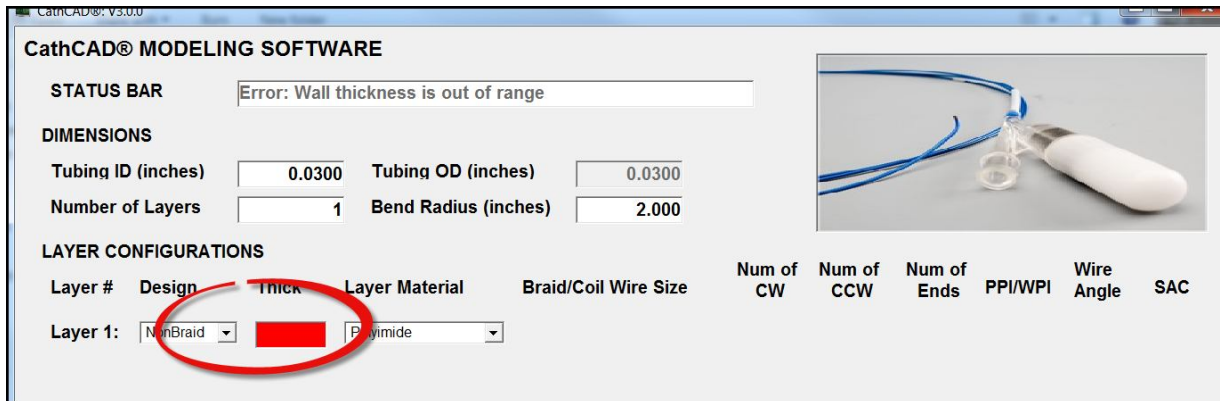

CathCAD® Model Outputs

The SOFTWARE computes the following outputs:

- EI is an estimate of the catheter flexural rigidity
- EA is an estimate of the catheter longitudinal rigidity
- GJ is an estimate of the catheter torsional rigidity
- The Kink radius is an estimate of the smallest radius the catheter will make in an UNLOADED (no axial force applied or internal pressure applied) condition. This computation assumes a perfectly manufacturer catheter (i.e. perfect concentricity and manufactured to nominal dimensions).
 - Two values are provided
 - The first value is the estimated kink radius due to buckling
 - The second value is the estimated kink radius due to material failure
- X_ID and Y_ID are the major and minor diameters of an ellipse at the User defined bend radius (computed per the Brazier algorithm)
- Failure mode computations:
 - Tensile strength (yield and ultimate)
 - Maximum torque
 - Internal Burst pressure: This parameter is process dependent. The model assumes that everything in the construction is "perfect." Perfect means no voids, perfect concentricity, and perfect lamination between layers. As a result, the computed values for burst pressure should be used as **REFERENCE ONLY** and the results should be validated with actual testing of the actual catheter construction.
 - External pressure failure ("crush")

V. Material and Braid Wire Data

The SOFTWARE allows for changes to the material inputs (i.e. matrix materials, braid wire sizes, # of braid wires) to be configured without recompiling. The materials and braid wire sizes are stored on a MySQL server running on our LINUX Server that is connected to the Internet.

If you have a requirement to add a new material, braid wire size, and/or # of braid wires, contact us at sales@cathcad.com and we will add your new material for you. After we load the data, the next time you run the SOFTWARE, the new item will appear automatically. A base configuration of materials/braid wires has been preloaded for your company. The list of available materials, braid wires, etc can be customized at no charge for your company.

Note that any customization of materials, braid wires, etc is proprietary for your company and will only appear for you.

VI. Exporting Modeling Results to Microsoft Excel

The SOFTWARE integrates directly with Microsoft Excel if this program is loaded on your computer. The combination of the SOFTWARE and Excel eliminates the requirement to write your results down on paper. Instead, the SOFTWARE directly exports the results directly to a standard model output format. This section explains how to export your results from the SOFTWARE to Excel.

1. When a design has been entered and computed, the **EXPORT TO EXCEL** button will become visible. This is your indication that the SOFTWARE has loaded the results into memory and is ready to export the results to Excel.

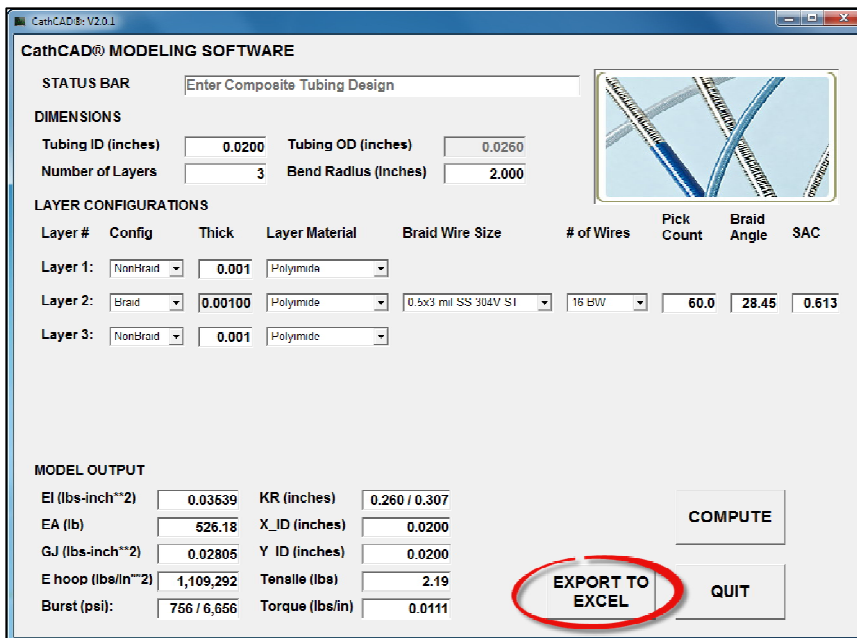

2. Select the **EXPORT TO EXCEL** button.

a. The **EXPORT TO EXCEL** will become faded.

b. Within a brief period of time (depending on your computer speed this may be as long as five to ten seconds) the **VIEW EXCEL** button will become active.

c. An instance of Excel has become active but is currently **HIDDEN** from your view. This instance of Excel contains your computed model data.

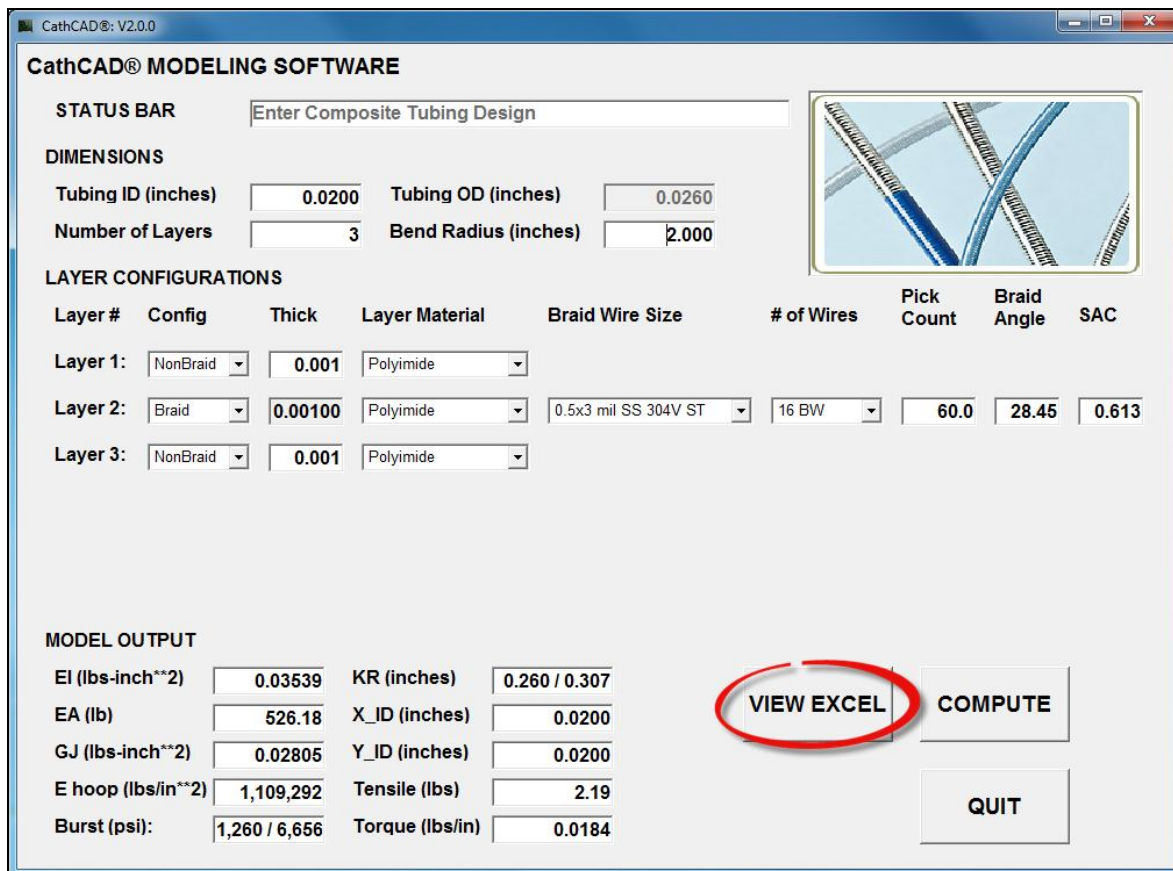

3. This process of entering models into the SOFTWARE, Computing, and Exporting to Excel can be repeated over and over. With time the User will gain confidence in this Excel export capability.

4. Viewing and working with your exported model results in Microsoft Excel is accomplished by the **VIEW EXCEL** and **HIDE EXCEL** button on the Main Menu.

- a. When Excel is hidden but contains data, the **VIEW EXCEL** button becomes active. Simply select this button and Excel will become **VISIBLE** allowing you to access your data directly. Likewise when the **SOFTWARE** is running and Excel is visible, the **HIDE EXCEL** button becomes active. This button allows you to have Excel active but not visible on your desktop.
- b. When you exit or quit the **SOFTWARE**, the Excel worksheet will become visible with your data.
- c. Your model results, as stored and formatted in Excel, is ready for immediate printing if you export five or less model runs. If you export more than six or more model runs to the same Excel spreadsheet, the printed results may be too small to read. As a result, the User may need to manually format the Excel spreadsheet to improve its printability.
- d. It is the User's responsibility to **SAVE** the results within Excel.
- e. A Project Number is automatically generated by the **SOFTWARE** for each model that is exported to Excel. This allows the User to identify a particular model run by a unique identifier. An example of the complete project number for an exported model run would be RT100000-01. The project number format is described as follows:
- Project numbers are configured to start with the account User's initials (e.g. RT)
 - Project numbers (by default) start at 100000.
 - Individual exported model runs begin with 01 and increment by one. If four models were exported to the same Excel spreadsheet, they would be identified as RT100000-01, RT100000-02, RT100000-03, and RT100000-04.
 - An example of the exported **SOFTWARE** generated format to Excel is provided on the next page which clearly illustrates the project number.
- f. The **SOFTWARE** makes its best efforts to interface to Excel properly. The User should not perform the following operations:
- Close Excel if the **SOFTWARE** has opened it. The **SOFTWARE** expects Excel to be available once it has launched it. If you do mistakenly close Excel, the **SOFTWARE** does its best to reopen Excel for export purposes in a graceful manner.
 - Delete rows and/or columns in Excel while the **SOFTWARE** is working with Excel.
- NOTE:** It is the User's responsibility to **SAVE** and store the resulting Excel file. While the **SOFTWARE** will export the model results to Excel, the **SOFTWARE** does not **SAVE** the results to a file.
- g. The example below shows the results for four model runs that were generated from the **SOFTWARE** and exported to Excel using the **EXPORT TO EXCEL** button.

EXPORT TO EXCEL FORMAT

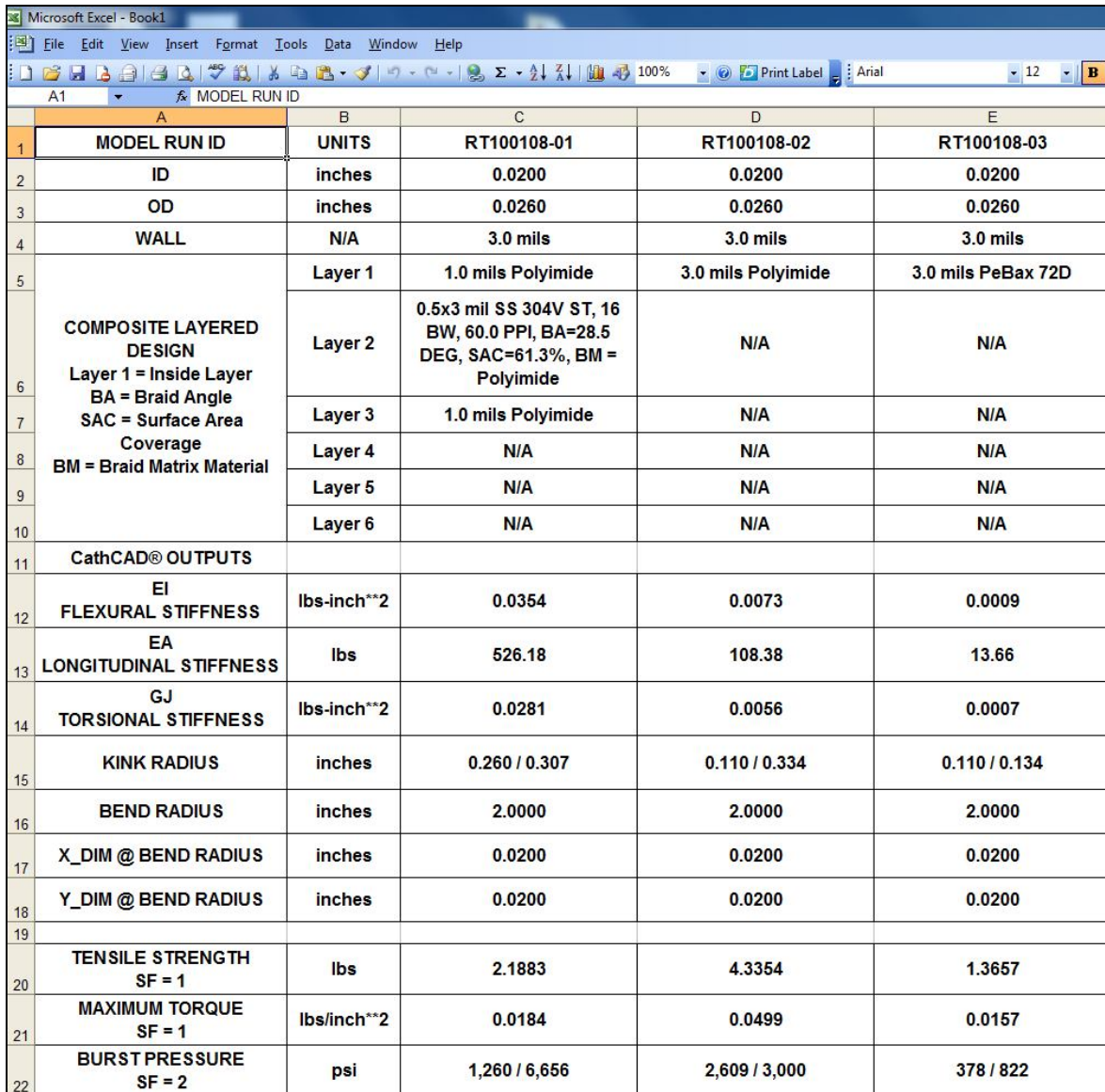

	A	B	C	D	E
	MODEL RUN ID				
1	MODEL RUN ID	UNITS	RT100108-01	RT100108-02	RT100108-03
2	ID	inches	0.0200	0.0200	0.0200
3	OD	inches	0.0260	0.0260	0.0260
4	WALL	N/A	3.0 mils	3.0 mils	3.0 mils
5	COMPOSITE LAYERED DESIGN Layer 1 = Inside Layer BA = Braid Angle SAC = Surface Area Coverage BM = Braid Matrix Material	Layer 1	1.0 mils Polyimide	3.0 mils Polyimide	3.0 mils PeBax 72D
6		Layer 2	0.5x3 mil SS 304V ST, 16 BW, 60.0 PPI, BA=28.5 DEG, SAC=61.3%, BM = Polyimide	N/A	N/A
7		Layer 3	1.0 mils Polyimide	N/A	N/A
8		Layer 4	N/A	N/A	N/A
9		Layer 5	N/A	N/A	N/A
10		Layer 6	N/A	N/A	N/A
11	CathCAD® OUTPUTS				
12	EI FLEXURAL STIFFNESS	lbs-inch**2	0.0354	0.0073	0.0009
13	EA LONGITUDINAL STIFFNESS	lbs	526.18	108.38	13.66
14	GJ TORSIONAL STIFFNESS	lbs-inch**2	0.0281	0.0056	0.0007
15	KINK RADIUS	inches	0.260 / 0.307	0.110 / 0.334	0.110 / 0.134
16	BEND RADIUS	inches	2.0000	2.0000	2.0000
17	X_DIM @ BEND RADIUS	inches	0.0200	0.0200	0.0200
18	Y_DIM @ BEND RADIUS	inches	0.0200	0.0200	0.0200
19					
20	TENSILE STRENGTH SF = 1	lbs	2.1883	4.3354	1.3657
21	MAXIMUM TORQUE SF = 1	lbs/inch**2	0.0184	0.0499	0.0157
22	BURST PRESSURE SF = 2	psi	1,260 / 6,656	2,609 / 3,000	378 / 822

If you have a particular format that you wish to use for your purposes -- please contact us.

VII. Coil Reinforced Modeling

This section applies to **CathCAD® Advanced** only.

The SOFTWARE offers modeling of coil reinforced constructions. Coil reinforced composite tubing may be modeled by specifying the following:

- For the applicable layer, setting the layer DESIGN to **Coil**
- Specifying the layer (matrix) material for the Coil reinforced layer
- Selecting the Coil Wire Size
- Select the Number of Individual (evenly spaced) coil wires are in the design via the drop down box. Currently -- this is limited to the values between 1 Wire and 12 Wires.
- The number of Wire Ends is set identically to 1 Strand.
- Entering the Wraps per Inch (WPI)

When all the other applicable fields are completed, select the COMPUTE button. An example of this capability is illustrated below. Please note that the SOFTWARE does not compute the internal pressure capability for this composite tubing type.

It was determined that the current algorithm utilized for nonbraid and braid reinforced composite tubing was not adequate for computing the pressure capability of coil reinforced composite tubing.

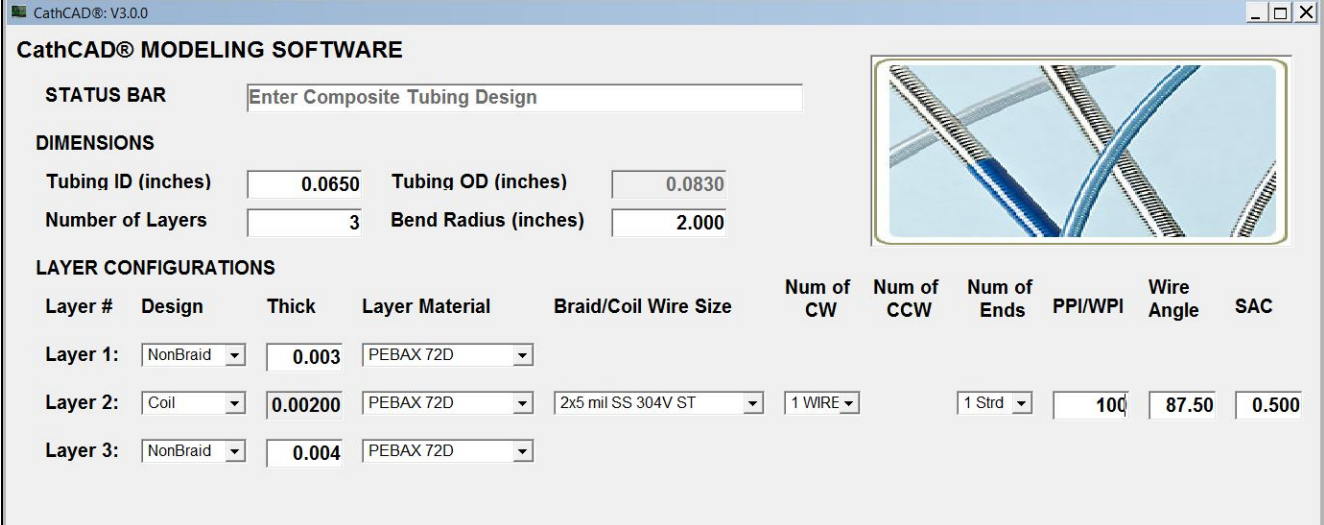

The screenshot displays the CathCAD® MODELING SOFTWARE interface. The window title is "CathCAD®: V3.0.0". The main title is "CathCAD® MODELING SOFTWARE".

STATUS BAR: Enter Composite Tubing Design

DIMENSIONS

Tubing ID (inches)	0.0650	Tubing OD (inches)	0.0830
Number of Layers	3	Bend Radius (inches)	2.000

LAYER CONFIGURATIONS

Layer #	Design	Thick	Layer Material	Braid/Coil Wire Size	Num of CW	Num of CCW	Num of Ends	PPI/WPI	Wire Angle	SAC
Layer 1:	NonBraid	0.003	PEBAX 72D							
Layer 2:	Coil	0.00200	PEBAX 72D	2x5 mil SS 304V ST	1 WIRE		1 Strd	100	87.50	0.500
Layer 3:	NonBraid	0.004	PEBAX 72D							

An inset image shows a 3D model of a blue coil-reinforced composite tubing section.

VIII. Multi-Stranded Braid Layer Designs

This section applies to **CathCAD® Advanced** only.

In the case of braid reinforced designs, the SOFTWARE offers the capability to model multi-stranded braid design. This capability is only available with round braid wires.

In the physical world, multi-stranded braiding is commonly done in the coaxial cable industry. It allows for higher braid surface area coverage while at the same time provides lower braid angles. As a result, the resulting braiding of the coax cable can be done faster.

In order to model multi-stranded braid designs, the following must be completed:

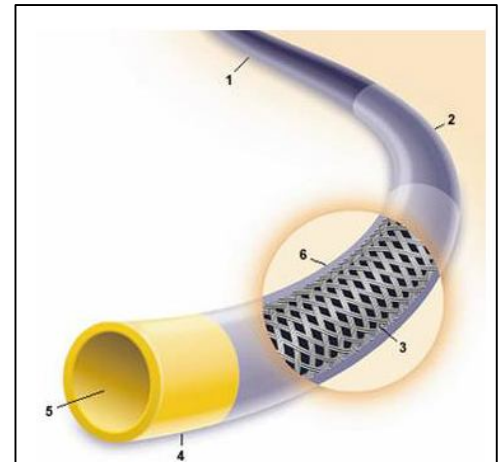

- For the applicable layer, set the layer DESIGN to Braid
- Select the Braid Layer Material
- Select the Braid Wire Size
- Select the Number of CW (Clockwise) wires in the design. For braided designs, the CCW will be automatically set to the number of CW wires (i.e. they must be equal).
- Select the Number of Strands. If the selected wire is a round wire, the SOFTWARE will allow to select up to a four (4) Stranded Design. If the selected wire is a flat wire, the SOFTWARE will only allow you to set the number of strands to one (1).
- Enter the pick count (PPI) for the braid layer
- Enter all the other applicable layers information
- Select the Compute button

CathCAD®: V3.0.0

CathCAD® MODELING SOFTWARE

STATUS BAR Enter Composite Tubing Design

DIMENSIONS

Tubing ID (inches) 0.0650 Tubing OD (inches) 0.0800

Number of Layers 3 Bend Radius (inches) 2.000

LAYER CONFIGURATIONS

Layer #	Design	Thick	Layer Material	Braid/Coil Wire Size	Num of CW	Num of CCW	Num of Ends	PPI/WPI	Wire Angle	SAC
Layer 1:	NonBraid	0.00150	PTFE							
Layer 2:	Braid	0.00400	PEBAX 72D	2 mil rd SS 304V ST	8 BW	8 BW	2 Strd	80	66.15	0.577
Layer 3:	NonBraid	0.00200	PEBAX 72D							

IX. Hybrid Braid Modeling

This section applies to **CathCAD® Advanced** only.

Hybrid braiding is defined where the braid wires in the catheter construction are different. The following are offered as examples:

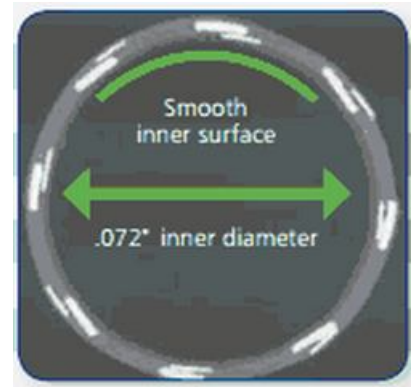

- Simple: In a 16 braid wire design, the eight (8) CW braid wires are 0.7x5 mil SS 304V and the eight (8) CCW braid wires are 0.5x3 mil SS 304V.
- Complex: In a 16 braid wire design, the eight (8) CW braid wires are defined as six (6) 1.5 mil rd SS 304V and two (2) 1.5 mil rd Tungsten wires. The eight (8) CCW braid wires are defined as 1 mil rd SS 304V.

The SOFTWARE allows for up to three different wires in the CW direction and up to three different wires in the CCW direction.

- The number of wires in the CW direction must add up to 4, 8, 12, or 16 wires as well as in the CCW direction. However, the number of wire types in the CW direction may be differ from the CCW direction
- The total number of CW wires must equal to the number of CCW wires.
- With this release, the SOFTWARE will allow a Hybrid Braid Layer confirmation for Layers 2 and/or Layer 3 ONLY.
- The largest (the braid wire with the largest height dimension) MUST be in the first position.

The following screen shot illustrates a Hybrid Braid design where the eight (8) CW braid wires are 1x5 mil SS 304V and the eight (8) CCW braid wires are 0.5x3 mil SS 304V. Multi-strand modeling is also included in Hybrid modeling IF the braid wire is round.

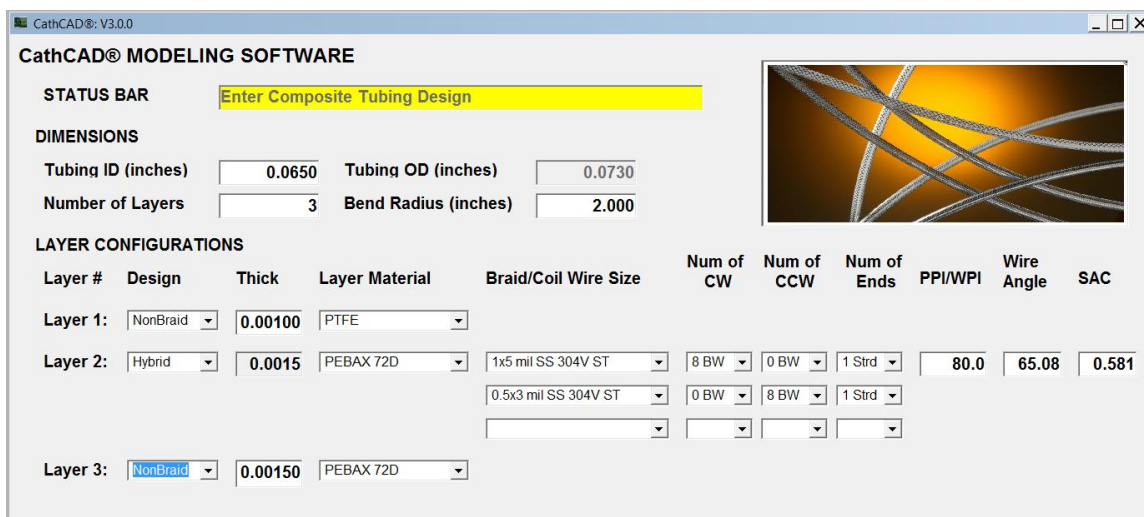

X. Pick Count Macro and Graphing

This Section applies to both **CathCAD® Standard** and **CathCAD® Advanced**.

In order to simplify the modeling of composite tubing, the SOFTWARE was updated to include the Pick Count Macro feature. This feature can be applied to the following configurations:

- Varying the pick count for braided or hybrid braided composites
- Varying the wraps per inch for coil reinforced composites. Yes -- it is called a Pick Count Macro but we have applied the concept to the WPI for coiled designs.
- NOTE: The design must have only ONE reinforcing layer. If the design has more than one reinforcing layer, the Pick Count macro applies to the layer that is CLOSEST to the Inner Diameter of the design.

To proceed with the Pick Count Macro function, complete the following steps:

- Enter a valid design into the SOFTWARE. The design MUST be BRAIDED or COIL reinforced. Select the Pick Count Macro (1)
- The SOFTWARE will review your design. If it is proper, the Pick Count Macro designer will appear on the screen. Enter the start, end, and pick count step sizes (2). Select the START button to proceed or RETURN to cancel the operation (3)

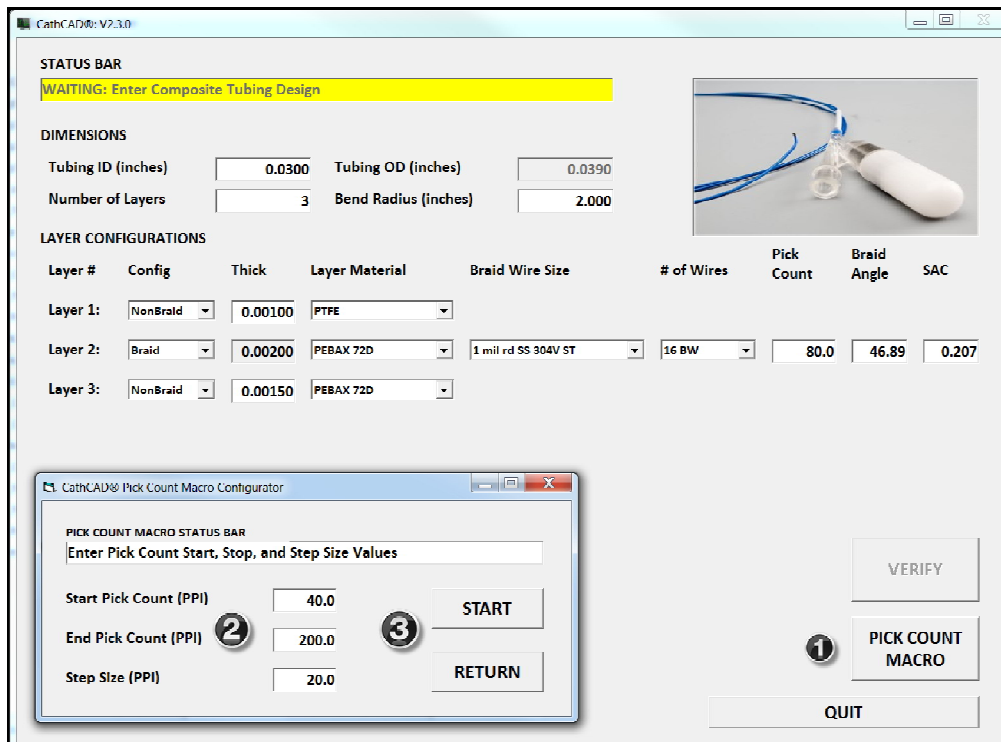

- The SOFTWARE will loop through the pick count limits automatically. When it is completed, the GRAPHING utility will appear on the screen allowing the User to review the SOFTWARE outputs as a function of pick count.

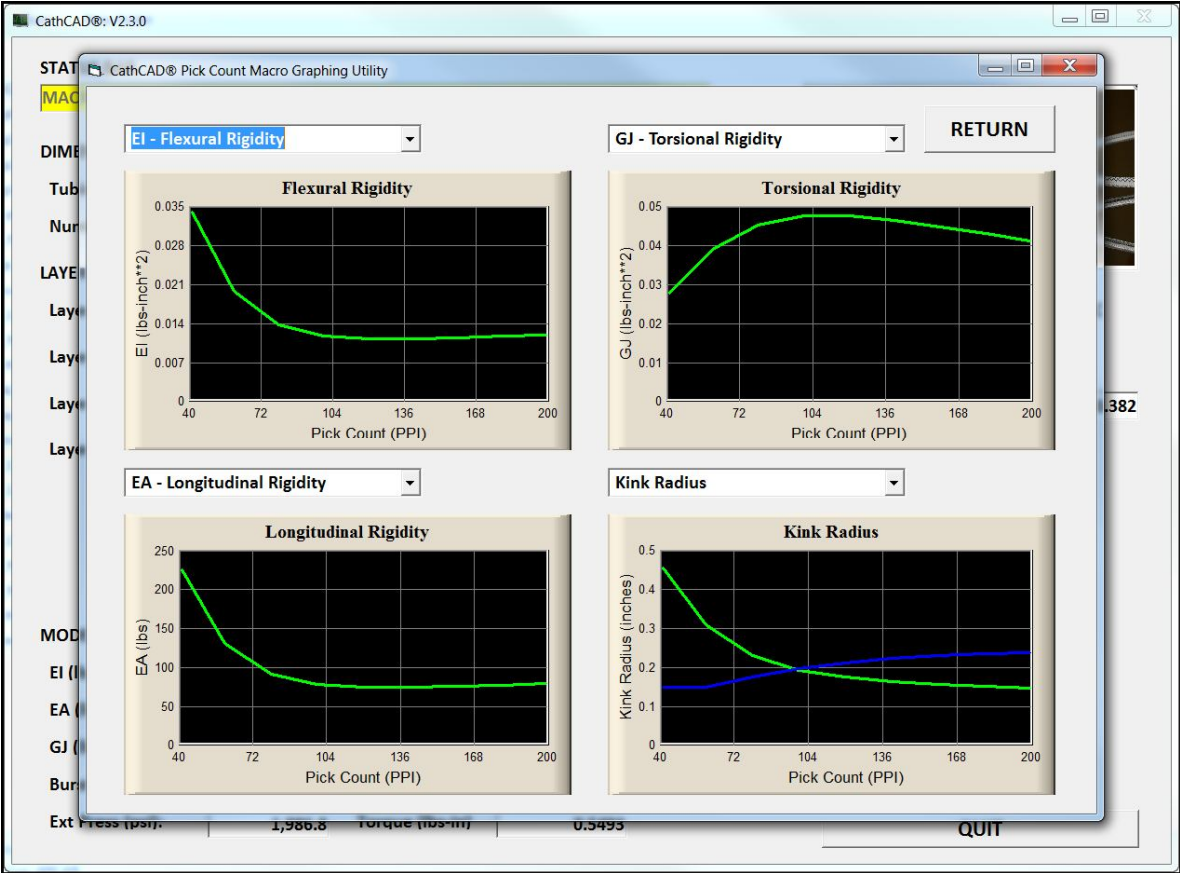

- To EXPORT the graphical results to Microsoft Excel select the EXPORT menu item at the top of the screen. This function will export two screens with all relevant graphs directly to Microsoft Excel.

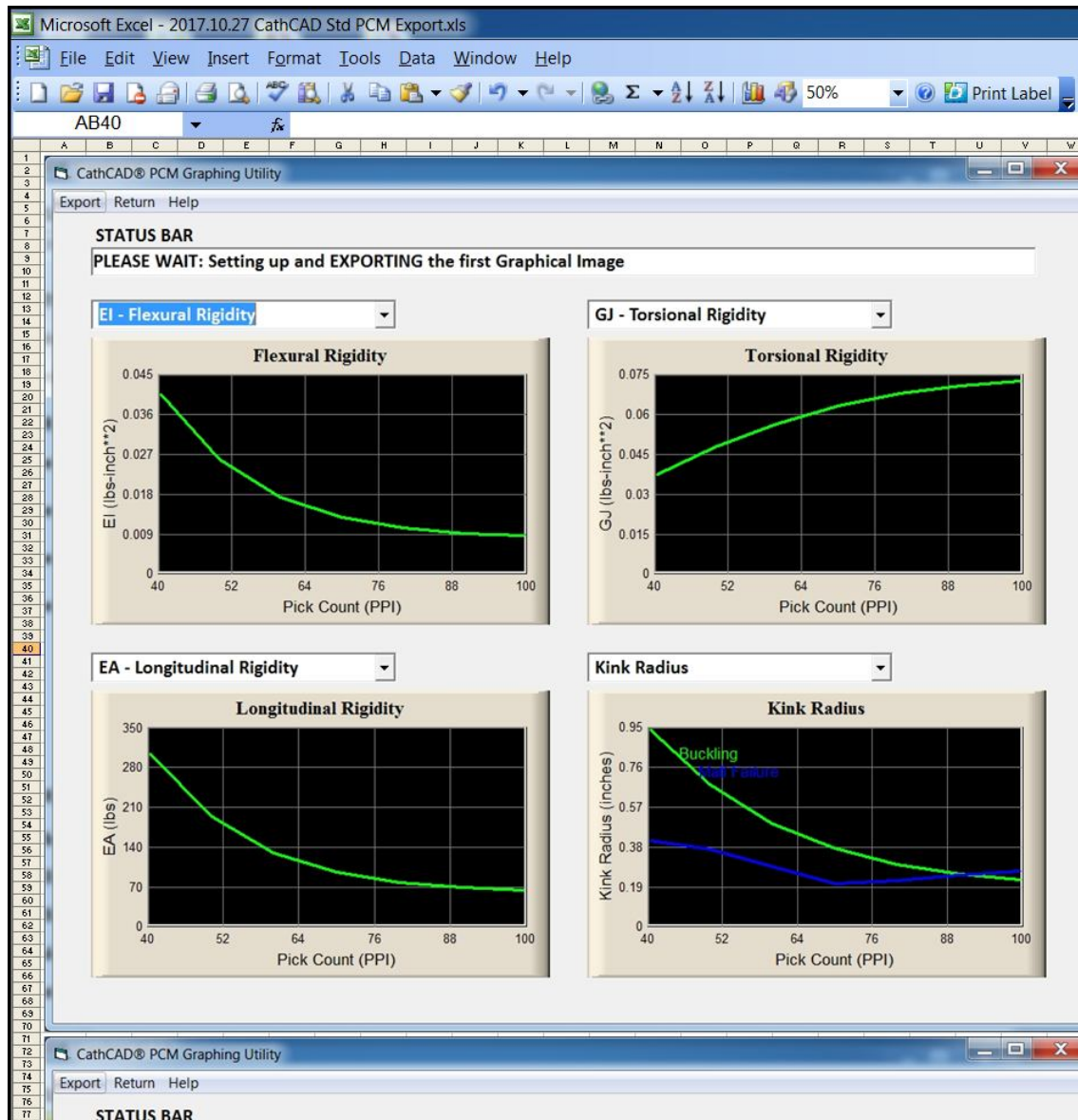

When you are completed reviewing the results, select the RETURN button on the screen. The results of the computation will also be exported (automatically) to Microsoft Excel as well. This process can generate a lot of data quickly so don't be surprised if there are many columns of data in Excel for you to review and look at as well.

XI. Material Blending

The latest release(s) of CathCAD® Standard and Advanced allow the User to generate on the fly material blends. The User may mix two selected matrix materials and combine them in the specified percentages. The material properties for the newly created material are computed automatically using established Rules of Mixtures. In order to create a new material blend select the [BLEND MATRIX MATERIALS] function from the Main form.

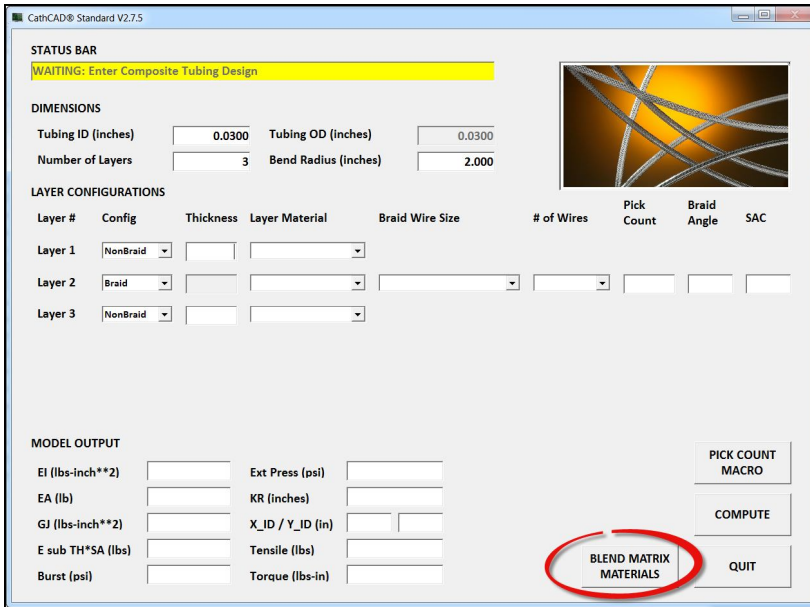

The Matrix Material Blend Function allows the User to easily create a custom material by the following procedure.

- Select the matrix materials to blend.
- The blend percentage is set by the [% Volume] Knob.
- Assign the blended matrix material name
- Select SAVE

The material created will appear at the bottom of your matrix materials drop down combo box for the current session only.

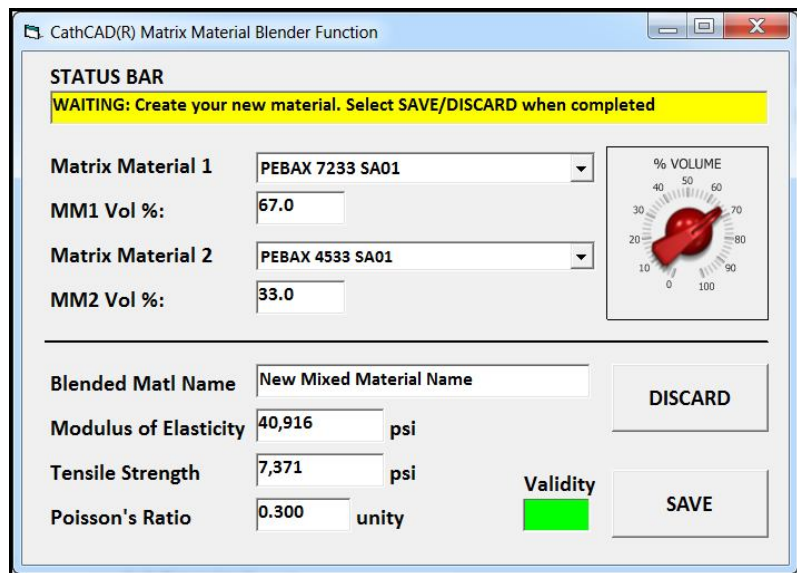

XII. Saving Project Designs

The release of CathCAD® Standard V2.7.6 and CathCAD® Advanced V3.7.8 introduced the capability of saving and restoring project designs. The project designs are tied to the SOFTWARE user. The Project Designs are saved on our MySQL Server. The number of stored projects are (at the time this User manual was released) was released to 100.

The following procedure is to be followed in order to SAVE a project design.

- Enter a complete (valid) project design
- Compute the project design by selecting the COMPUTE button
- Export the project design to Microsoft Excel. This process step assigns a project number to the design.
- Finally -- select the SAVE button. This function saves the project design (tied to the User's account) to our MySQL Server for future recall.

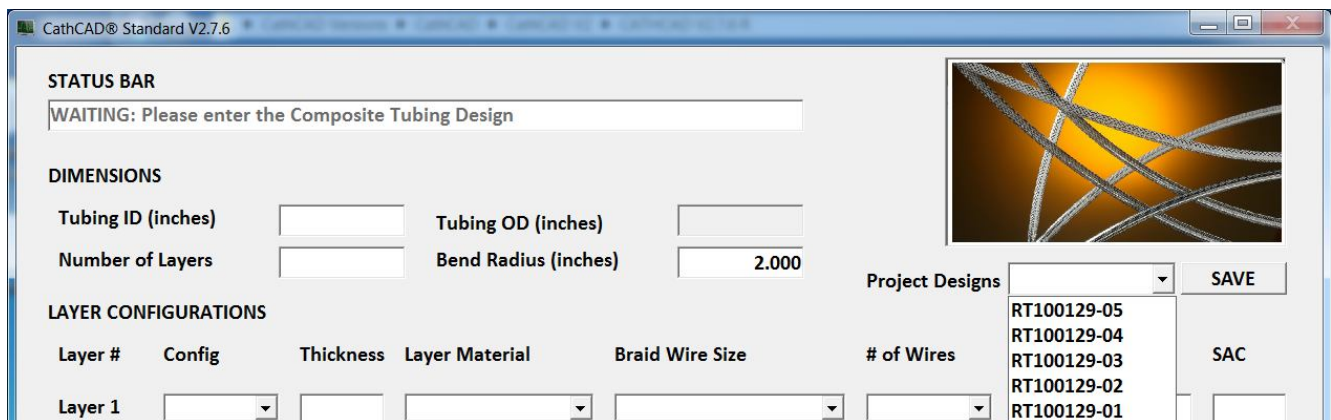

In order to RELOAD a project design, select the applicable project design from the drop down dialog box located next to the Project Designs title on the data entry form. The SOFTWARE will ask for permission to reload the design before proceeding.

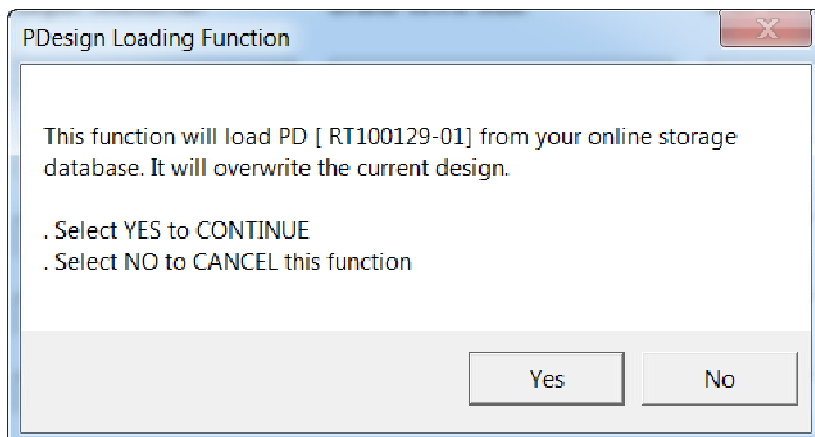

Upon reloading the project design the SOFTWARE will compute and compare the output results as compared to when the project was originally saved. If the results compare within 0.1 percent the reload is considered successful as illustrated in the following screenshot.

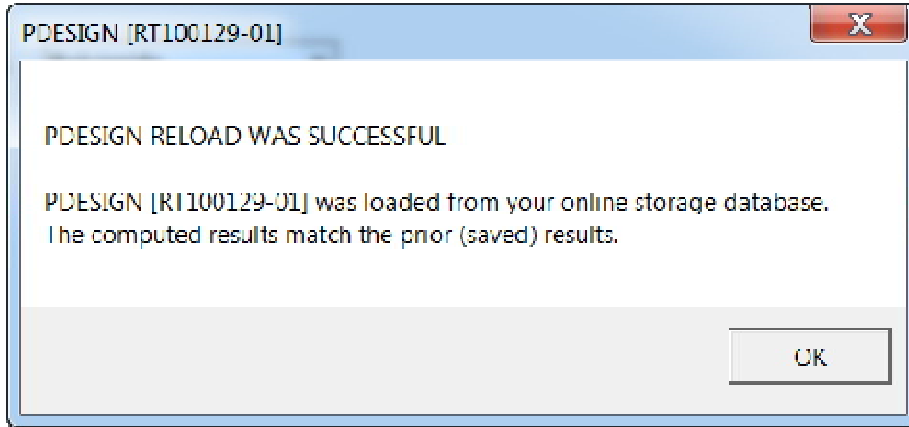

If there are issues during the reload process AND/OR the computed results differed from the original (saved) results the following message box will be displayed to the User.

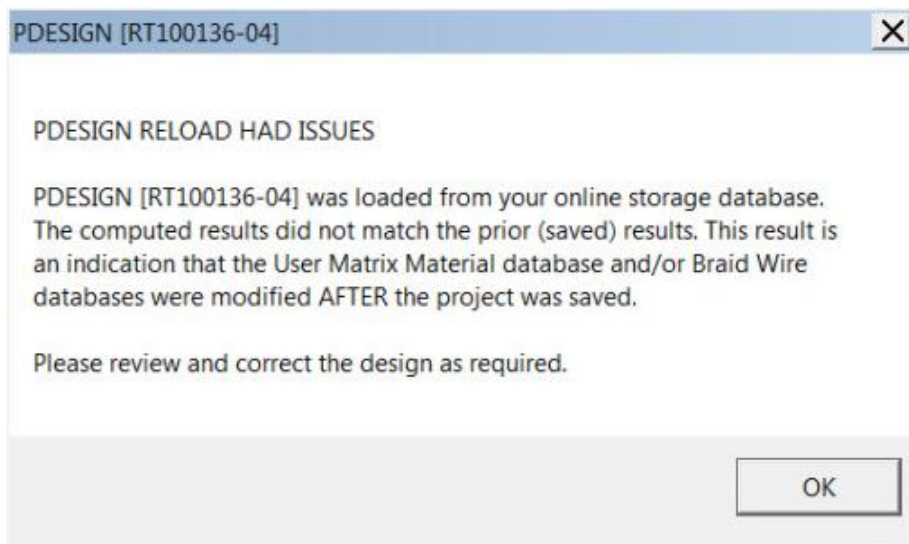

XIII. CathACCESS®

For our sophisticated Users of the SOFTWARE, we offer the ability to directly interface to the MySQL materials database with our utility program, CathACCESS®.

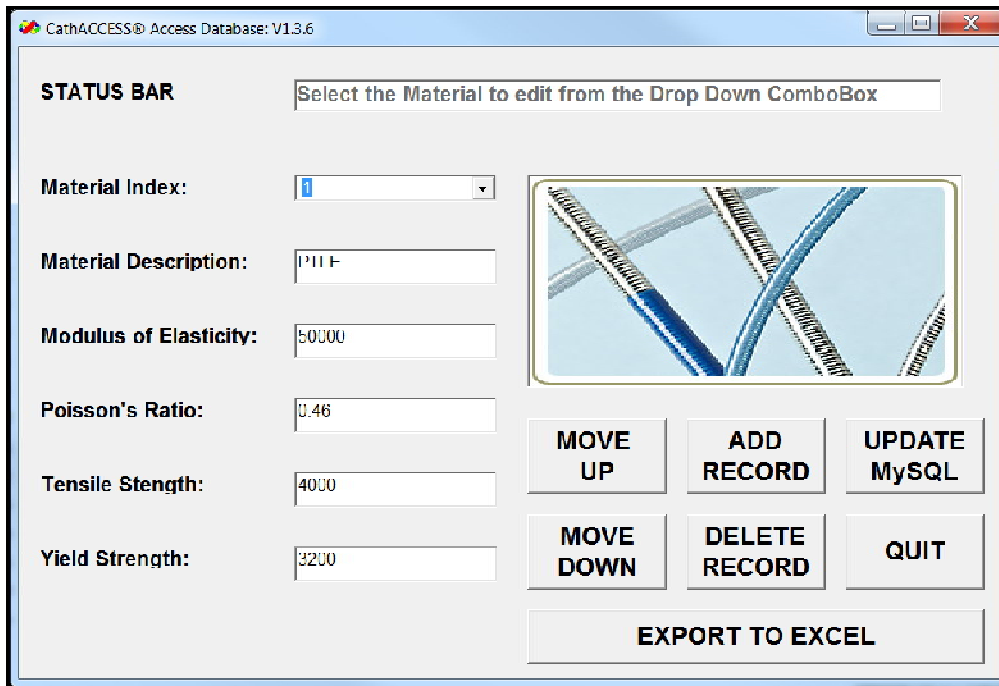

CathACCESS® allows you to do the following:

- **UPDATED RECORD:** Update a Material record including Material Description, Modulus of Elasticity, Poisson's Ratio, Tensile Strength, and Yield Strength
- **ADD RECORD:** Add a New Material
- **DELETE RECORD:** Delete a Record from the Materials Database
- **EXPORT TO EXCEL:** This exports all records from the Database to Excel.

Contact us via email at sales@cathcad.com in order to be configured for use of this program.

XIV. Reporting Errors or to Request Feature Updates

Report system crashes or situations where the SOFTWARE generates incorrect results via email to sales@cathcad.com. Please provide as much information as possible with regards to the setup of the program when the error occurred.

We also encourage and accept feature requests from our Users. Please email these requests to sales@cathcad.com as well.